

# Safety & Installation Instructions

v1.5-11.23

# DP0749 Marine Mast Light Instruction Manual

These instructions are provided for your safety in order to prevent the risk of Fire, Electric shock or Injury. It is vitally important that they are read in their entirety before installing your fitting. Please retain for future reference.

1. If you are in any doubt consult a qualified electrician as to the installation of the fitting. Install in accordance with current IEE wiring regulations. It is recommended that this fitting is installed by a qualified electrician.
2. Ensure that the electrical supply is OFF. Disconnect the electrical supply at the fuse-board.
3. If removing an existing fitting first, note all wiring connections: record which of the house wires is connected to the live, neutral and earth terminals.
4. Carefully identify where the supply cable is (and check there are no other cables in the area) to avoid damage to concealed wiring during installation.
5. Position the light where desired ensuring that there is suitable support adjacent to where you will connect to the house supply and mark position of fixing holes, before drilling appropriate holes as below.
6.
  - a. Brick or masonry: Drill holes into which the wall plugs tightly fit, then insert wall plugs.
  - b. Wood: No hole necessary (unless small pilot hole required), screws can be screwed directly into the timber.
  - c. Plaster/Cavity: Special cavity wall fittings are required, rather than provided fixings. These are widely available from good hardware or DIY store and should come with their own instructions that must be followed. It may be easier to relocate the fitting so that you screw directly into a timber joist or beam.
7. Support the fitting so that no strain is applied to the wiring when making the electrical connections. If necessary get a colleague to help.
8. Electrical connection: this light fitting must be earthed. Make connections following the diagram below, using the terminal block provided. A small flat-head screwdriver is required. Please note that the supplied lampholder has no polarity - both of the wires connected to the lampholder are white. Please ensure one of the white wires is connected to live and one is connected to neutral. The earth wire from the fitting **MUST** be connected to the earth termination.

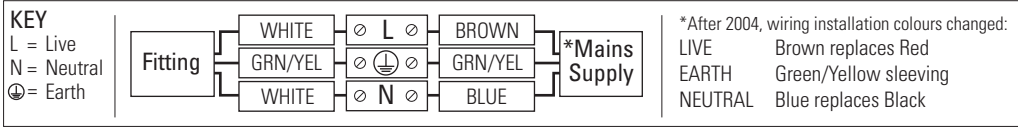

9. Double check all the connections are secure and that no loose strands of wire are left out of the connector. Ensure the lid of the terminal block is closed securely after making the connections.
10. Check that no wires are trapped behind or within the fitting and complete the installation, referring to the installation diagram inside.
11. Fit the correct type and wattage of lamp (or less). Be careful not to overtighten the lamp.
12. Switch on at the fuse-board. Your light fitting is now ready for use.

## Other Important Information

Switch off at mains before changing lamp(s). Never fit a lamp of greater wattage than recommended. Ensure children do not play with the light fitting. Dispose of old lamps carefully. Never leave a fitting without a lamp in position (or someone can accidentally touch the contacts). Adjust fitting only when power to the fitting is off and has been left to cool. If the external flexible cable or cord of this luminaire is damaged, it shall exclusively be replaced by the manufacturer or his service agent, or a similar qualified person, in order to avoid a hazard.

## Cleaning and Maintenance

Metal finishes should only be cleaned with a soft, dry cloth. Do not use polishes or abrasives. Glass can be cleaned by hand, using a soft damp cloth with a diluted mild detergent (nonabrasive) or suitable glass cleaner if necessary. Switch off power to the fitting before cleaning. Spare parts are available for this product, please contact us on the details below.

Established in 1990, Original BTC manufactures relaxed, familiar lighting for traditional and contemporary homes. All products are hand-assembled in Oxfordshire from high quality components, produced in the UK.

ORIGINALBTC.COM  
+44 (0)1993 882 251  
UNIT 21 / 22 AVENUE ONE, STATION LANE, WITNEY, OX28 4XZ, ENGLAND



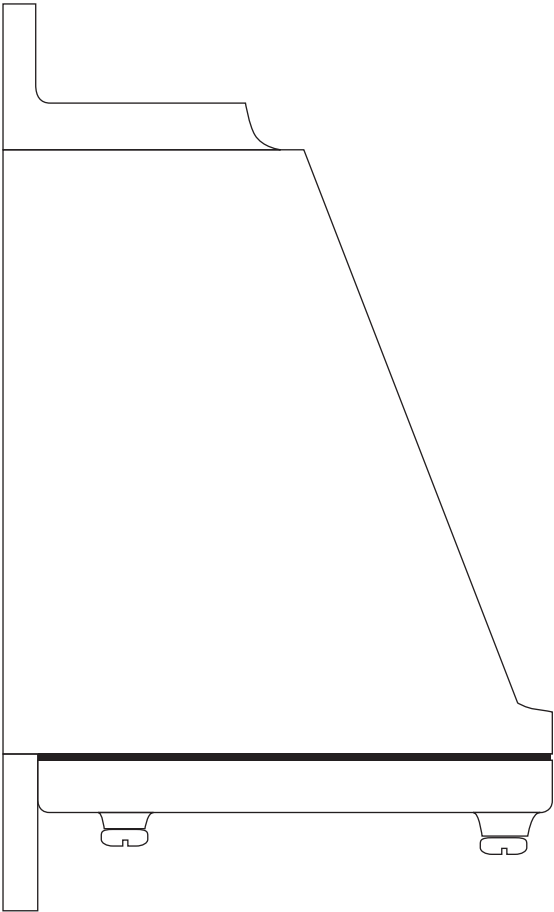

**ORIGINAL BTC**  
BRITISH LIGHTING MANUFACTURERS  
LONDON - PARIS



# DP0749 Mast Light

| 230V AC 50Hz | IP54 |

DP0749/AL/AN	Mast Light, Mains Voltage, Anodised Aluminium
DP0749/AL/SD/AN	Mast Light, Mains Voltage, Sandblasted Aluminium, Anodised
DP0749/GM/PO	Mast Light, Mains Voltage, Polished Bronze
DP0749/GM/SD	Mast Light, Mains Voltage, Sandblasted Bronze
DP0749/GM/SD/WE	Mast Light, Mains Voltage, Sandblasted Bronze, Weathered

LAMP GUIDANCE			
BASE	SHAPE	TYPE*	WATTAGE**
 GU10	 PAR16	HALOGEN ✓ LED ✓	35W MAX 6W

\* Warm white (2700k) low energy lamps recommended - supplied with 4.3W LED GU10.  
\*\* Wattage value provided as a guide to suitable lamps. Lower wattage than stated may be used.

## Contents

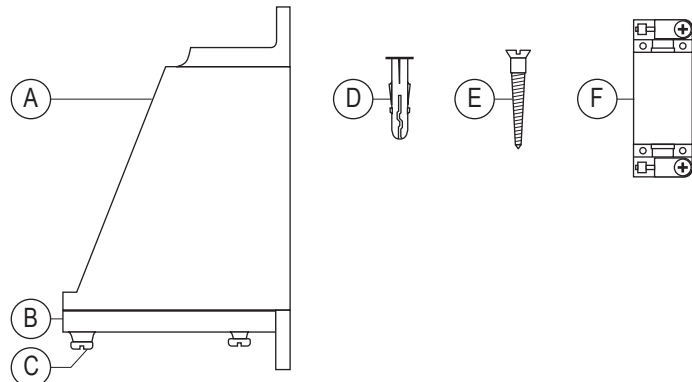

### Contents

- A - Mast light casting
- B - Mast light door
- C - Door screw (x3)
- D - Rawl plug (x2)
- E - Fixing screw (x2)
- F - Connector

### Required for Installation

- Screwdriver, flat-head
- Small screwdriver, flat-head
- Drill (if holes are required)

## Supplied Lamp (Bulb) Energy Label

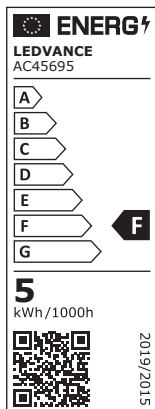

## Main Supply Cable Preparation

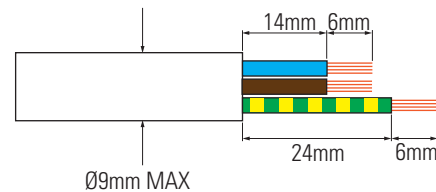

Please prepare the supply cable as shown. Note the maximum cable diameter for the supplied connector is 9mm, with the maximum conductor size 2.5mm<sup>2</sup>.

## Installation Diagram

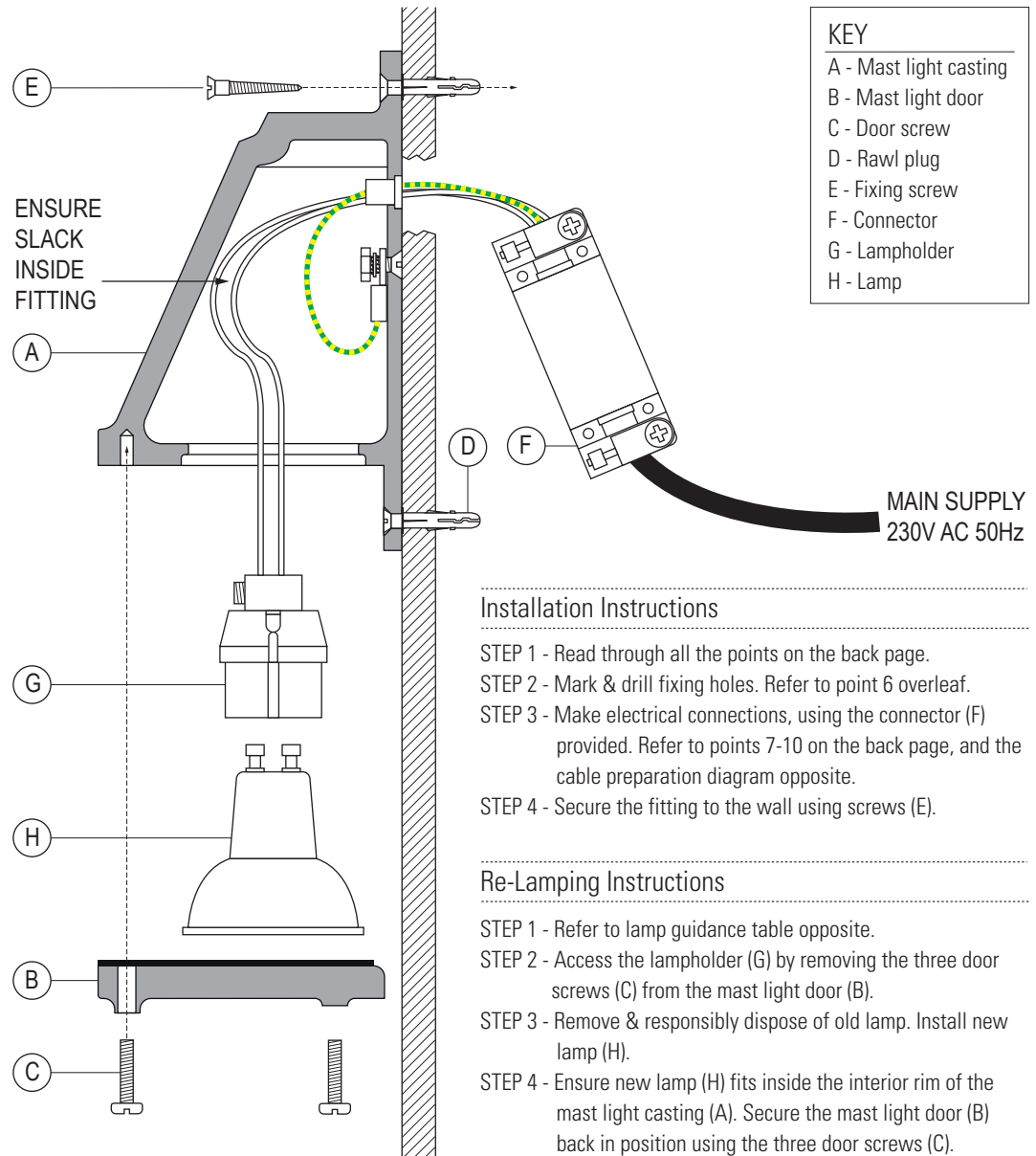

## Installation Instructions

- STEP 1 - Read through all the points on the back page.
- STEP 2 - Mark & drill fixing holes. Refer to point 6 overleaf.
- STEP 3 - Make electrical connections, using the connector (F) provided. Refer to points 7-10 on the back page, and the cable preparation diagram opposite.
- STEP 4 - Secure the fitting to the wall using screws (E).

## Re-Lamping Instructions

- STEP 1 - Refer to lamp guidance table opposite.
- STEP 2 - Access the lampholder (G) by removing the three door screws (C) from the mast light door (B).
- STEP 3 - Remove & responsibly dispose of old lamp. Install new lamp (H).
- STEP 4 - Ensure new lamp (H) fits inside the interior rim of the mast light casting (A). Secure the mast light door (B) back in position using the three door screws (C).

PLEASE READ THE INSTRUCTIONS ON THE REVERSE BEFORE YOU BEGIN INSTALLING YOUR LIGHT